

# 030/040/050 CAS 系列

转角油缸夹紧臂

Ordering example:

**CAS** - **352** **D**  
 Base No.      Size      Acting Type  
                   92        S: Single Acting  
                   202        D: Double Acting  
                   352

Dimensions

## Dimensions

Model	030 / 040 / 050					
	Single Acting			Double Acting		
	LS/RS-92	LS/RS-201/202	LS/RS-351/352	LD/RD-92	LD/RD-201/202	LD/RD-351/352
Arm No.	CAS-92S	CAS-201/202S	CAS-351/352S	CAS-92D	CAS-201/202D	CAS-351/352D
A	86	106	127	86	106	127
B	30	36	44	30	36	44
C	M10x1.5	M12x17.5	M16x2	M10x1.5	M12x1.75	M16x2
D	38	48	48	38	48	48
E	3.5	3.5	3.5	3.5	3.5	3.5
G	18	25	31	18	25	31
H	45	65	73	45	65	73
I	16	21	29	16	21	29
J	25	30	40	25	30	40
K	10.5	14	20	10.5	14	20
L	9.75	11	12.5	9.75	11	12.5
M	φ25	φ32	φ38	φ25	φ32	φ38
N	-----	-----	-----	18	20	25
O	-----	-----	-----	φ12.5	φ16.5	φ18.5
P	45	55	68	45	55	68
Q	M10x1.5	M12x17.5	M16x2	M10x1.5	M12x1.75	M16x2
T	11	15	15	11	15	15

公司地址：上海市静安区新闻路 1161 号 A1 室      邮编 200041  
 电话：021-51872743      传真：021-62275540  
 公司网站：[www.fdzc.net](http://www.fdzc.net)      E-mail:[chengff@sh163.net](mailto:chengff@sh163.net)

# 030/040/050 CAS 系列

## 转角油缸夹紧臂

Single Acting

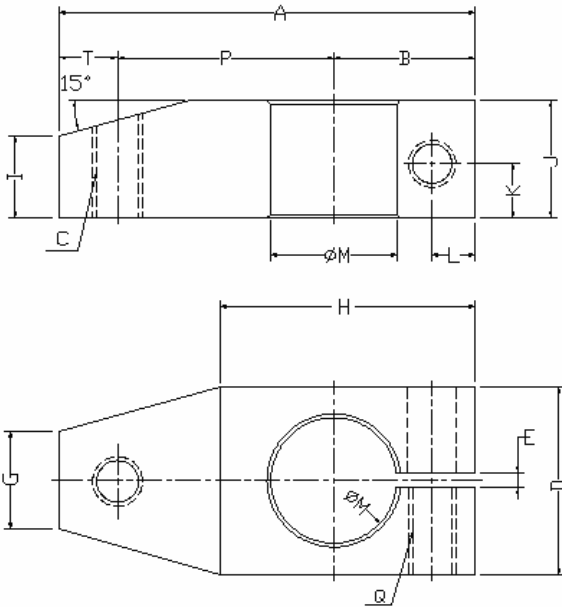

Double Acting

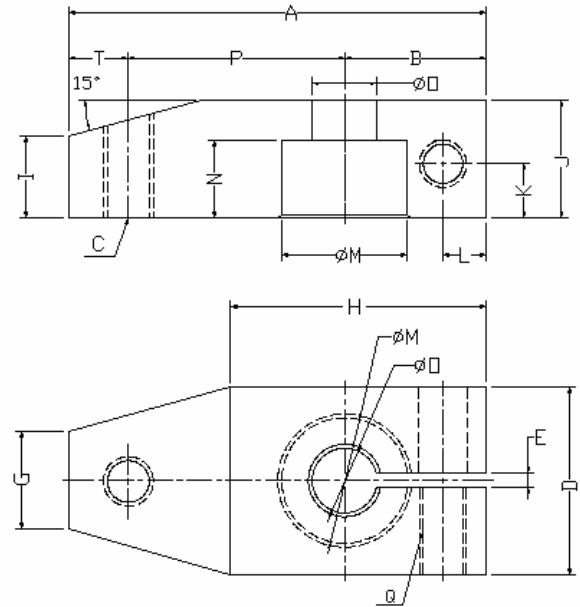

# 030/040/050 CAS 系列

转角油缸夹紧臂

## Pressure v.s. Clamping Force

